



Tarash Felez
شرکت تراش فلز آریسا

BaBel مشخمت شیرهای ویفری



BaBel

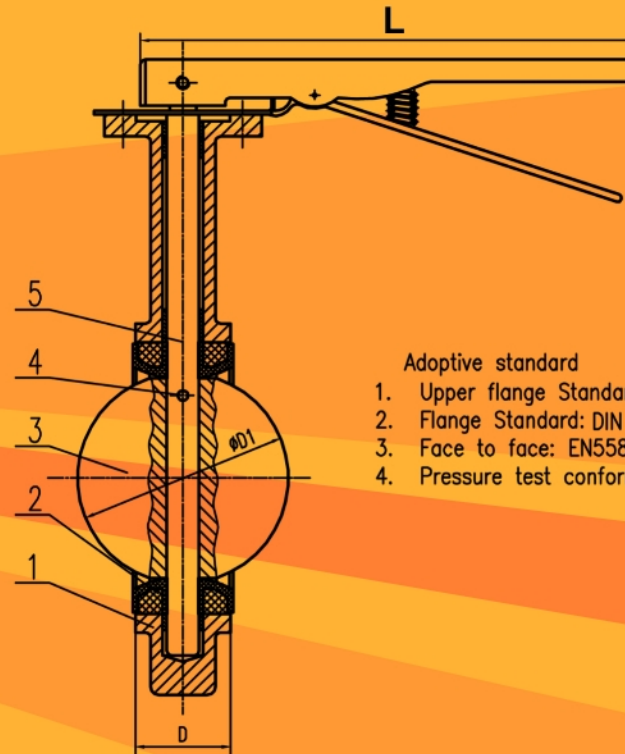
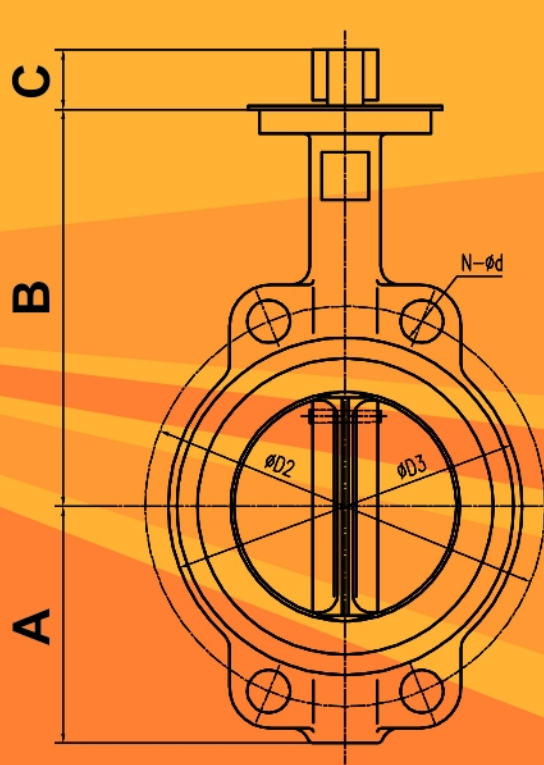

Adoptive standard

1. Upper flange Standard: ISO5211
2. Flange Standard: DIN 1092 PN16
3. Face to face: EN558-1,20
4. Pressure test conform to API598



Item	Part name	Material
1	Body	CI
2	Seat	EPDM
3	Disc	DI
4	Taper Pin	SS 416
5	Stem	SS 416

SIZE	A	B	C	ØD1	ØD3	ØD2	N Ød	D	L
DN50	65	155	22	52.6	100	125	4-19	40	255
DN65	75	160	24	64.3	120	145	4-19	42	255
DN80	95	167	24	78.8	127	160	8-19	42	255
DN100	105	181	24	104	156	180	8-19	49	255
DN125	118	191	26	123.3	190	210	8-19	52	276
DN150	129	206	29	155.7	212	240	8-23	52	276
DN200	175	260	41	202.4	268	295	12-23	60	383